

Dear Councillor

PLANNING COMMITTEE - TUESDAY, 22ND SEPTEMBER, 2020

Please find attached copies of the plans for the above meeting.

Agenda No Item

3. **AREA EAST - DETERMINATION OF PLANNING APPLICATIONS** (Pages 3 - 28)

4. **AREA SOUTH - DETERMINATION OF PLANNING APPLICATIONS** (Pages 29 - 54)

Yours sincerely

Wendy Walters

Chief Executive

Encs

Wendy Walters

Prif Weithredwr, Neuadd y Sir,
Caerfyrddin, Sir Gaerfyrddin SA31 1JP
Chief Executive, County Hall,
Carmarthen, Carmarthenshire SA31 1JP



BUDDSODDWYR | INVESTORS
MEWN POBL | IN PEOPLE

Mae croeso i chi gysylltu â mi yn y Gymraeg neu'r Saesneg

You are welcome to contact me in Welsh or English

Y Pwyllgor
Cynllunio

Planning
Committee

22.09.2020

RHANBARTH
Y DWYRAIN

AREA
EAST

Page 3



EICH CYNGOR **arleinamdani**
www.sirgar.llyw.cymru

YOUR COUNCIL **doitonline**
www.carmarthenshire.gov.wales

Agenda Item 3

**CEISIADAU YR
ARGYMHELLIR EU
BOD YN CAEL EU
CYMERADWYO**

**APPLICATIONS
RECOMMENDED
FOR APPROVAL**

Y Pwyllgor
Cynllunio

Planning
Committee

E/39554

Page 5



EICH CYNGOR arleinamdani
www.sirgar.llyw.cymru

YOUR COUNCIL doitonline
www.carmarthenshire.gov.wales

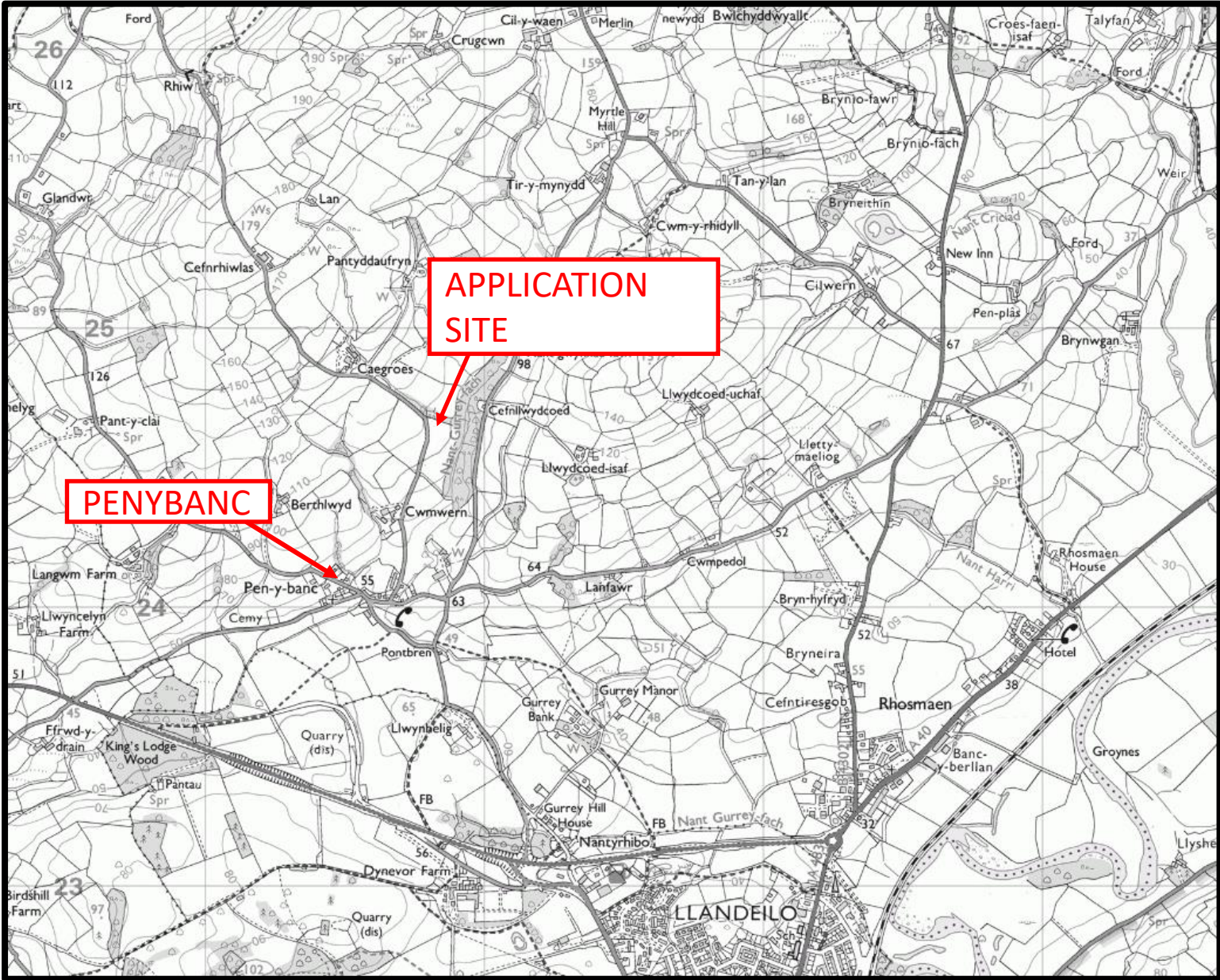

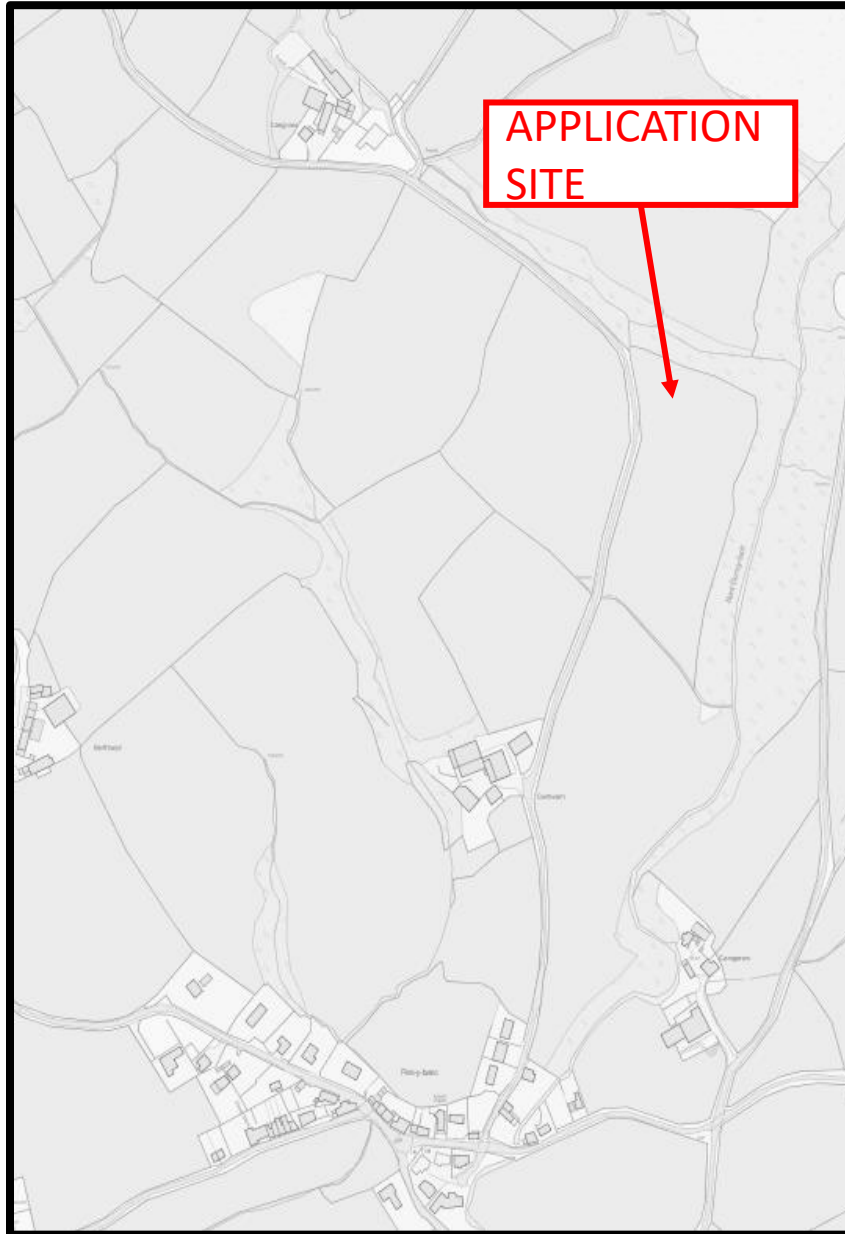

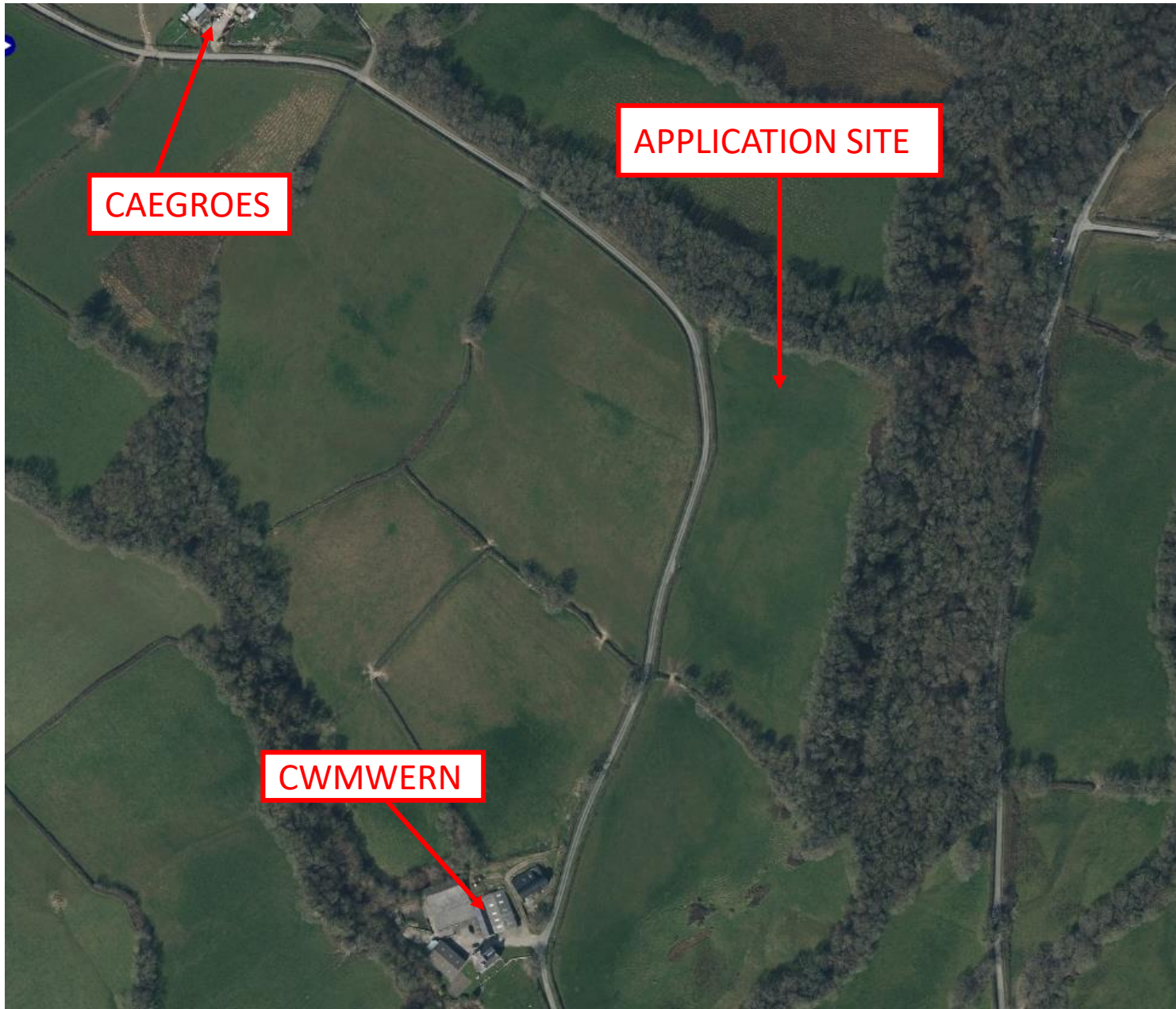

E/39554

AERIAL PHOTO





1:100

- Front south facing elevation
- Large doors and windows to maximize solar and thermal gain
- Externally larch clad
- Roof to be a live green roof

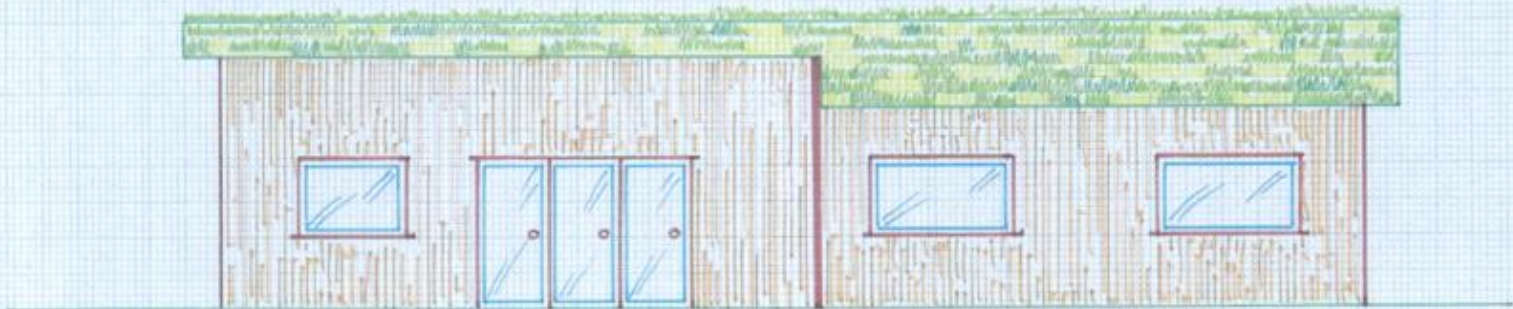
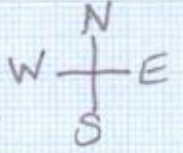

:100

- Side elevation
- Door to kitchen
- Window to kitchen
- Southern door provides entry to the childrens cwtch area
- Larch cladding
- Southern aspect of roof will be a live green roof.
- Highest point of roof 4.2m

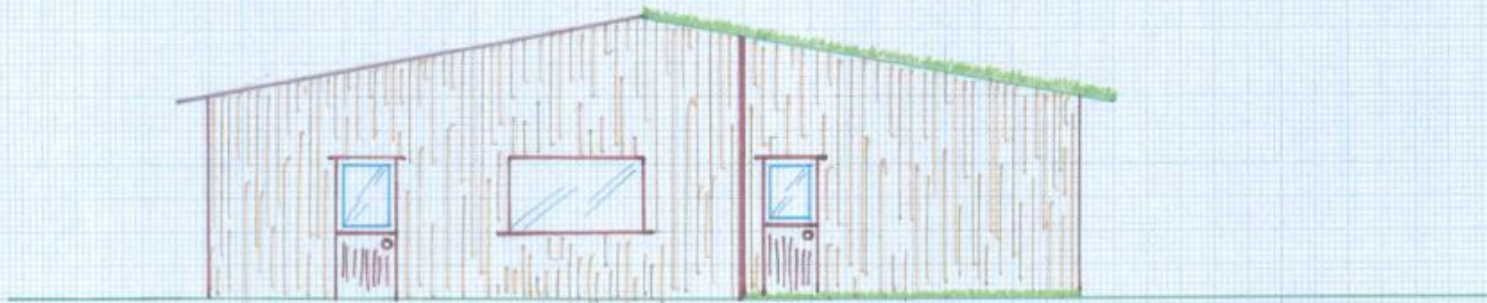
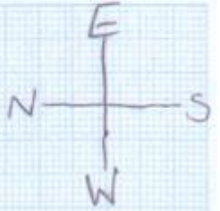

1:100

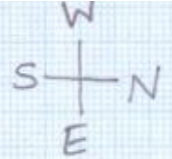

- Side Elevation
- 3 small windows
- Southern roof aspect will be a live green roof
- Rear northern roof used for rainwater Harvesting
- Externally the dwelling will be larch clad

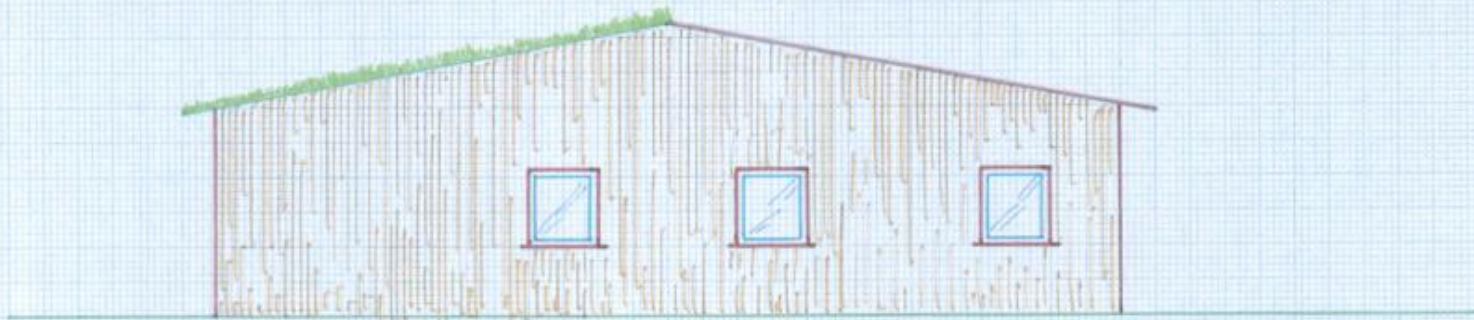

1:100

Floor Plan

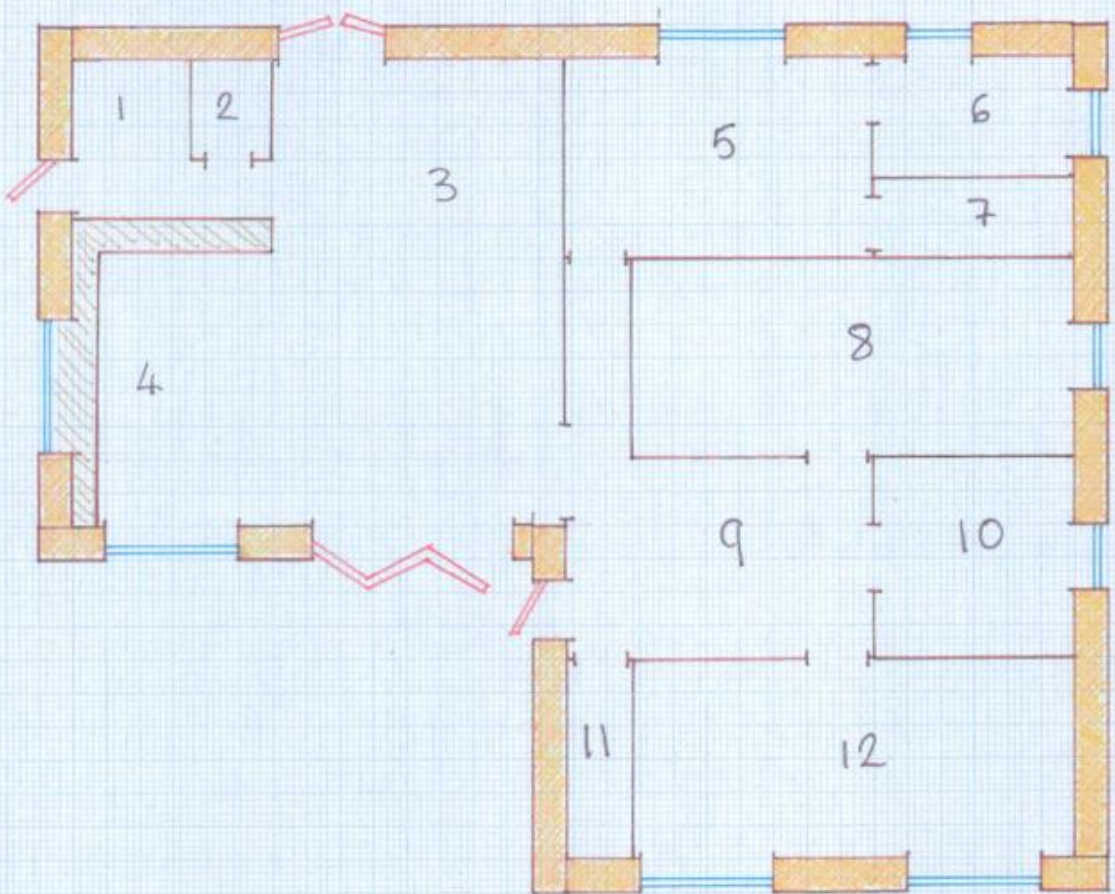
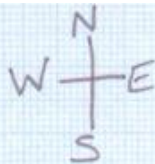

- 1. Boot room
 - 2. Pontry
 - 3. Living space
 - 4. Kitchen space
 - 5. Master bedroom
 - 6. Ensuite
 - 7. Storage
 - 8. Bedroom for 2 children
 - 9. Cwtch/Craft space
 - 10. Family bathroom
 - 11. Storage
 - 12. Bedroom for 2 children
- Windows
- External doors
- Strawbale insulation
- | Internal walls
- Kitchen Worktop

E/39554

SITE PHOTO



E/39554

SITE PHOTO

Page 16



E/39554

SITE PHOTO



E/39554

SITE PHOTO

Page 18



E/39554

SITE PHOTO



E/39554

SITE PHOTO



Page 20

E/39554

SITE PHOTO



E/39554

SITE PHOTO

Page 22



E/39554

SITE PHOTO



E/39554 SITE PHOTO-SITE OF DWELLING

Page 24



E/39554

SITE PHOTO-SITE OF DWELLING



E/39554

SITE PHOTO

Page 26



E/39554

SITE PHOTO



This page is intentionally left blank

Y Pwyllgor
Cynllunio

Planning
Committee

22.09.2020

RHANBARTH
Y DE

AREA
SOUTH

Page 29

Agenda Item 4



EICH CYNGOR **arleinamdani**
www.sirgar.llyw.cymru

YOUR COUNCIL **doitonline**
www.carmarthenshire.gov.wales

Y Pwyllgor Cynllunio

Planning Committee

**EITEM ER
GWYBODAETH**

**INFORMATION
ITEM**

Y Pwyllgor
Cynllunio

Planning
Committee

DNS/00422

Page 31



EICH CYNGOR arleinamdani
www.sirgar.llyw.cymru

YOUR COUNCIL doitonline
www.carmarthenshire.gov.wales

DNS/00422

Page 32

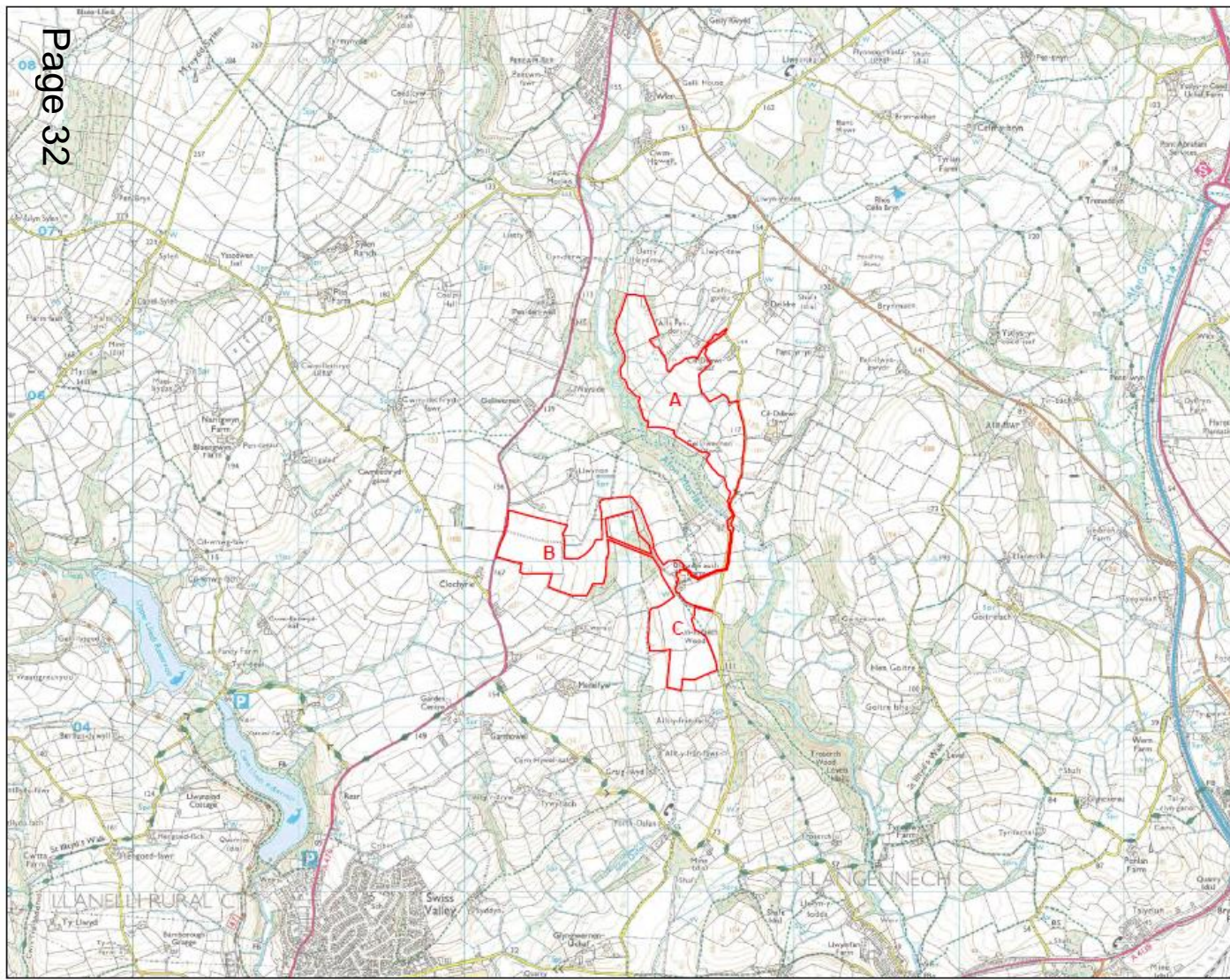

KEY
[Red outline] Site Boundary



Information based on all known constraints.
© Crown copyright. All rights reserved. 2014 Emapdata Licence number 0100051673. Ordnance Survey Copyright Licence number 100042093. Promap Licence number 100020449

6.1 | FIGURE

Site Location Plan | TITLE

1:25,000 @ A3 | SCALE
BRS.4254_22-B | DWG. NO.

DNS/00422

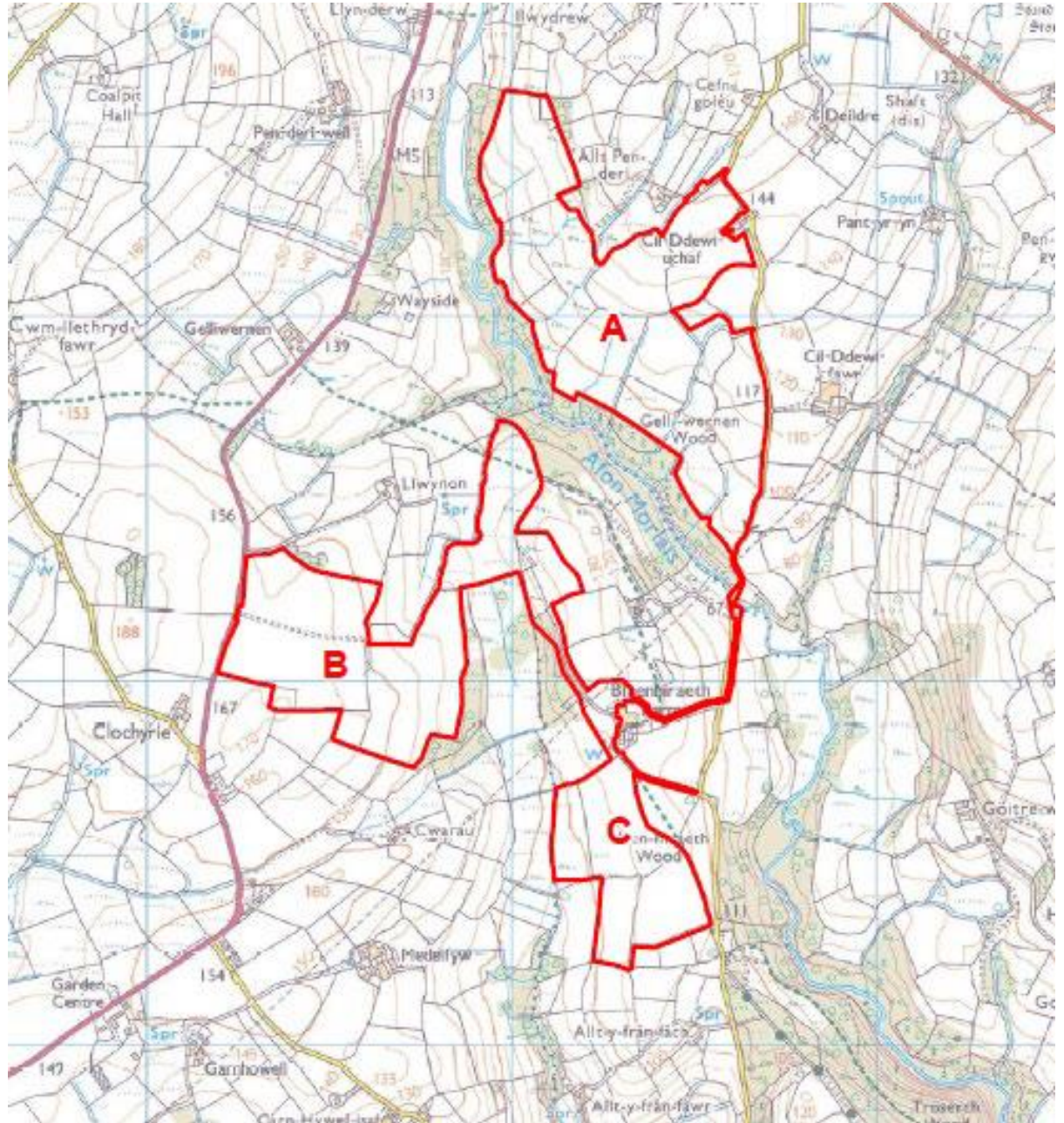

DNS/00422

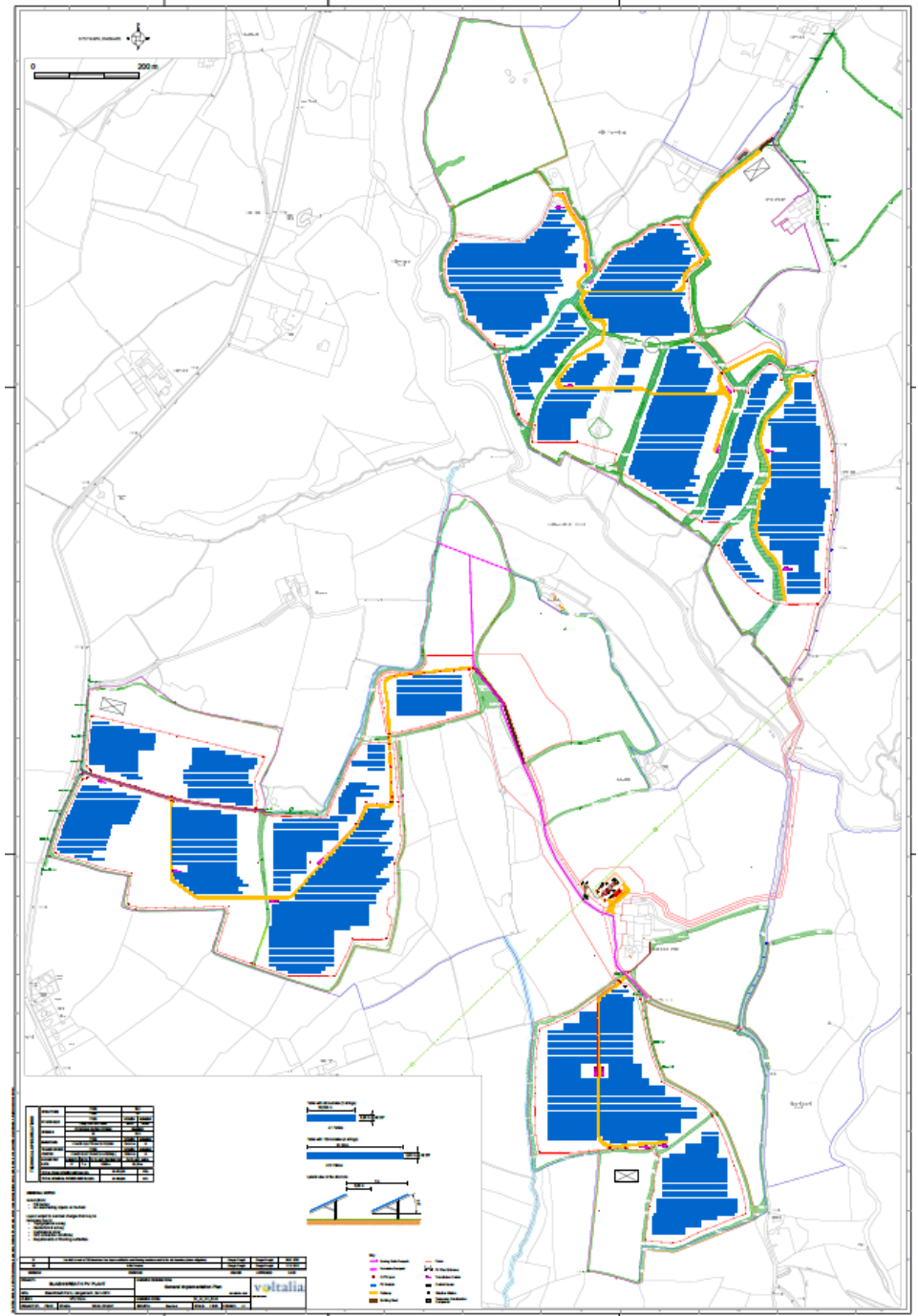

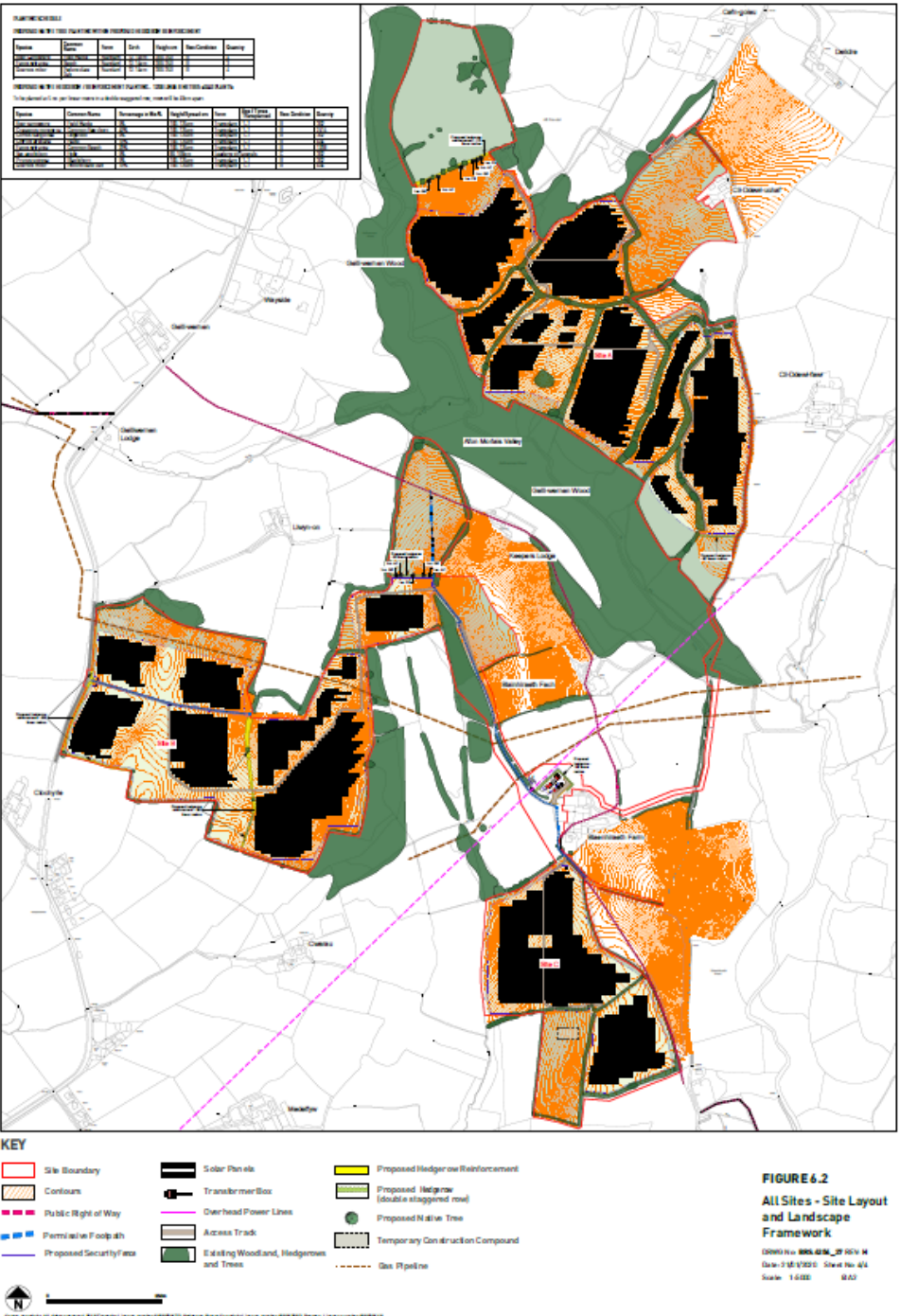
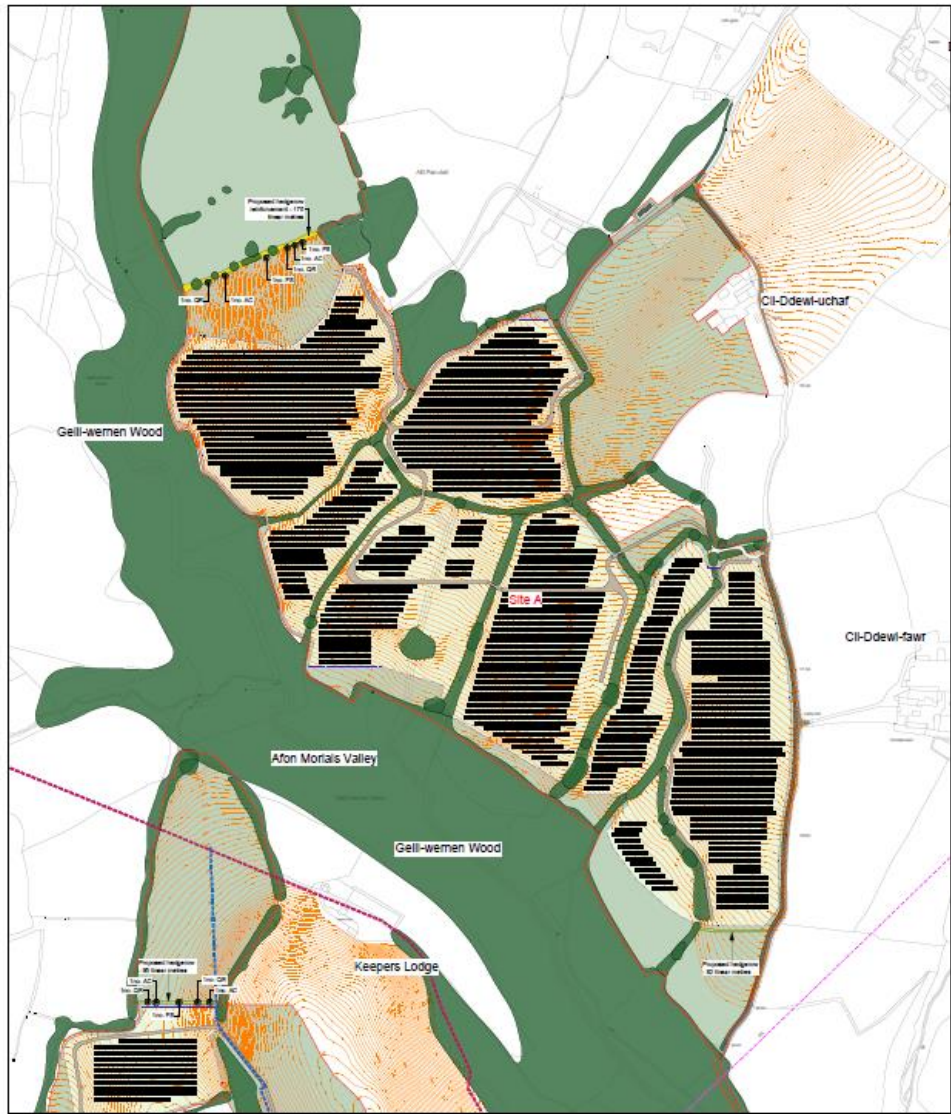

FIGURE 6.2
All Sites - Site Layout and Landscape Framework
 DNS/00422 - 000_02M_07 05/14
 Date: 18/12/2013 Sheet No: 4/4
 Scale: 1:6000 0/0



KEY

Site Boundary	Proposed Native Tree
Existing Woodland	Temporary Closed to Site or Compensated
Public Right of Way	
Permitted Footpaths	
Proposed or Existing Fences	
Existing Planting	
Translucent Site	
Closed to Public Access	
Existing Turf	
Existing Woodland, Hedgerows and Trees	
Proposed or Existing Field or Woodland	
Proposed or Existing Hedgerows (to be retained)	

FIGURE 6.2
Site A - Site Layout and Landscape Framework

DNS/00422



- KEY**
- Site Boundary
 - Contours
 - Public Right of Way
 - Permeation Footpath
 - Gas Pipelines
 - Proposed Security Fence
 - Solar Panels
 - Transformer Box
 - Overhead Power Lines
 - Access Track
 - Temporary Construction Compound
 - Existing Woodland, Hedgerows and Trees
 - Proposed Hedgerow Reinforcement
 - Proposed Hedgerow (double staggered row)
 - Proposed Native Trees

FIGURE 6.2
Site B - Site Layout and Landscape Framework
Drawn by: 888_422_07_1021_H
 Date: 3 10 2016 Sheet No: 3/4
 Scale: 1:200 8 A1

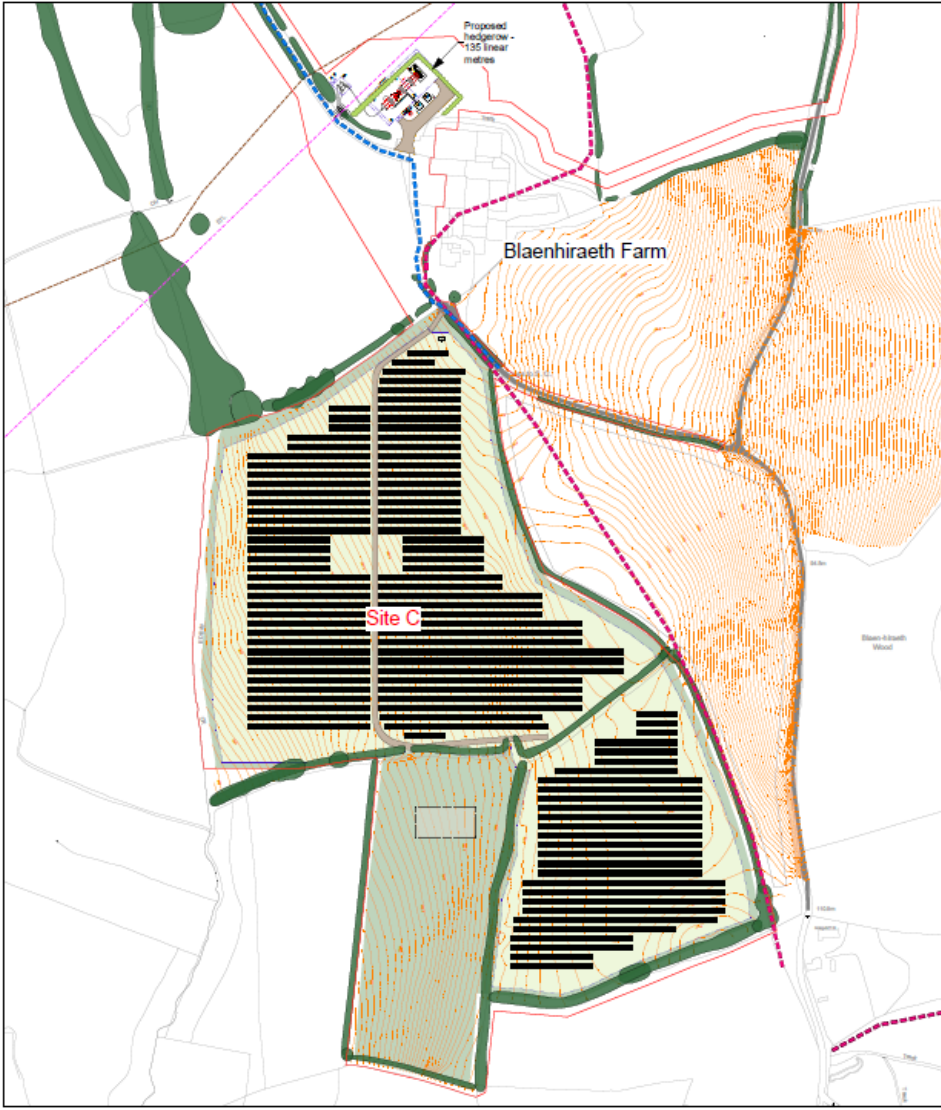

KEY

Site Boundary	Proposed Native Tree
Contours	Temporary Construction Compound
Public Right of Way	
Permitted Hedgerow	
Proposed Hedgerow	
Proposed Boundary Tree	
Sides Paths	
Transformer Site	
Overhead Power Lines	
Access Tracks	
Existing Woodland, Hedgerows and Trees	
Proposed Hedgerow	
Proposed Hedgerow	

FIGURE 4.2
Site C - Site Layout and Landscape Framework
10000 5000 0 5000 10000
Scale: 1:5000
Date: 11/20 2023

DNS/00422

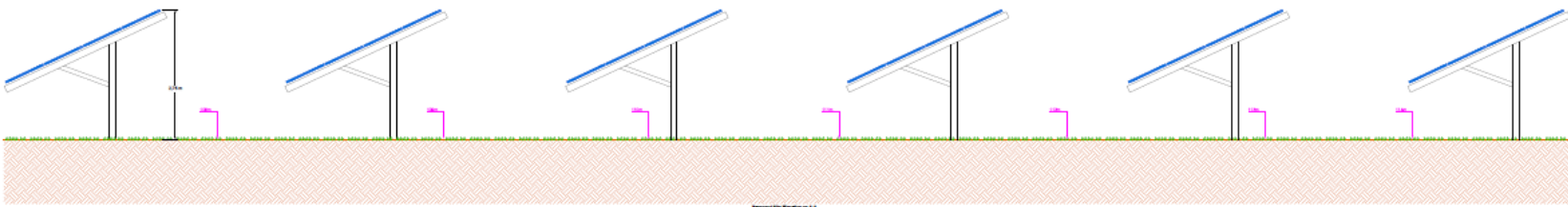

Page 39

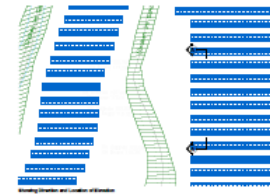

NO.	REVISION	DATE	BY	CHECKED
1	ISSUED FOR PERMIT	10/20/2023
2

Project: REDEVELOPMENT OF THE 1ST FLOOR Location: 1000 10th Street, San Francisco, CA 94103 Client: ... Architect: ... Date: 10/20/2023	
--	--

■ Existing
■ Proposed Elevations

Sections (Typical Table end With Collector Box)

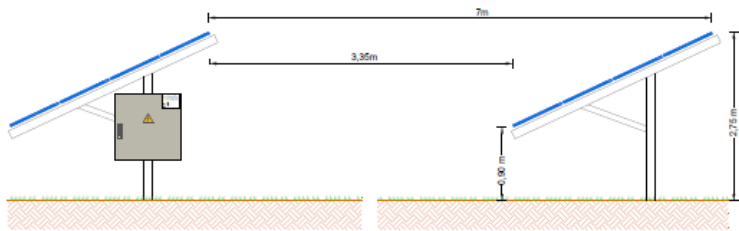

Sections (Typical Intermediate Table)

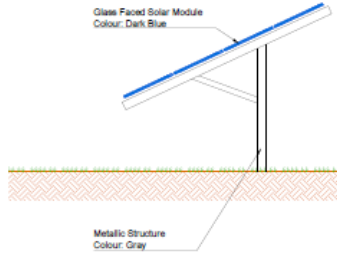

Sections (Typical Table end Without Collector Box)

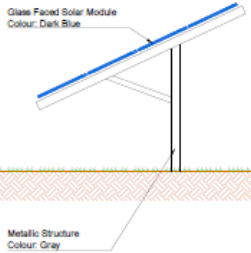

Typical Sections Out

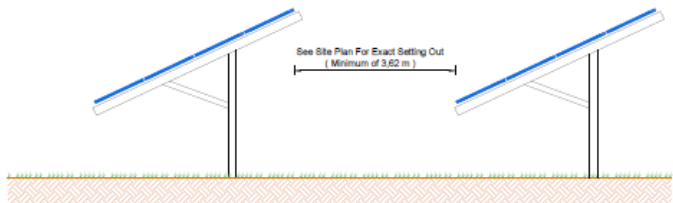

Rear Elevation

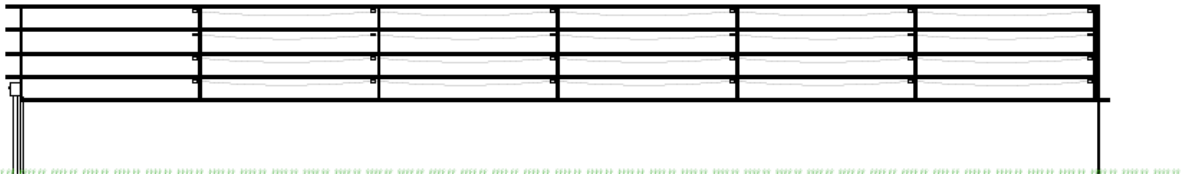

Front Elevation

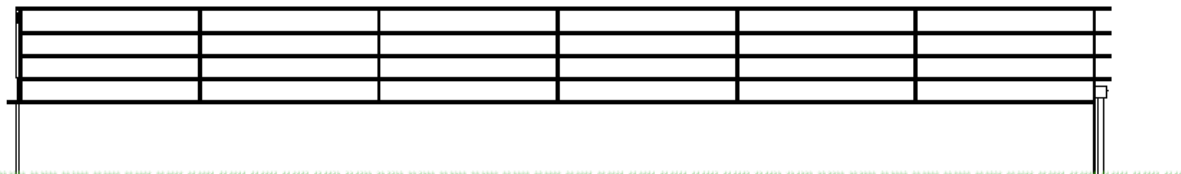

00	Initial Version	George Fungli	George Fungli	10.12.2019	
VERSION	PURPOSE	DRAWN	VERIFIED	DATE	
CLIENT:	-	DRAWN:	George Fungli	SERVICE:	Electrical
PROJECT:	BLAENHIREATH PV PLANT	VERIFIED:	George Fungli	STAGE:	Development
SITE:	Blasbriarth Farm, Llanermech, SA14 8PX	DATE:	10.12.2019	RELEASED BY:	GED
DRAWING DESIGNATION:	Mounting Structure	SCALE:	1:50	VOLTALIA UK	
		PROJECT N°:	PEM01	1 Lyric Square, Hammarbyh	
		FORMAT:	A2	WS DNS London, United Kingdom	
		DRAWING N°:	W0001_004_004_004_01	Tel: +44 203641094	

Copyright © 2019 by Voltaia UK. All rights reserved. This drawing is the property of Voltaia UK and shall not be reproduced, stored in a retrieval system, or transmitted in any form or by any means, electronic, mechanical, photocopying, recording, or by any information storage and retrieval system, without the prior written permission of Voltaia UK.

DNS/00422

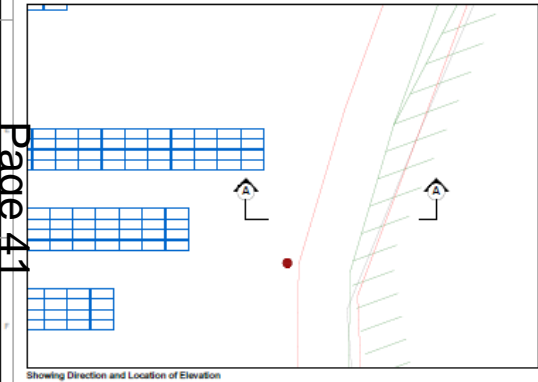
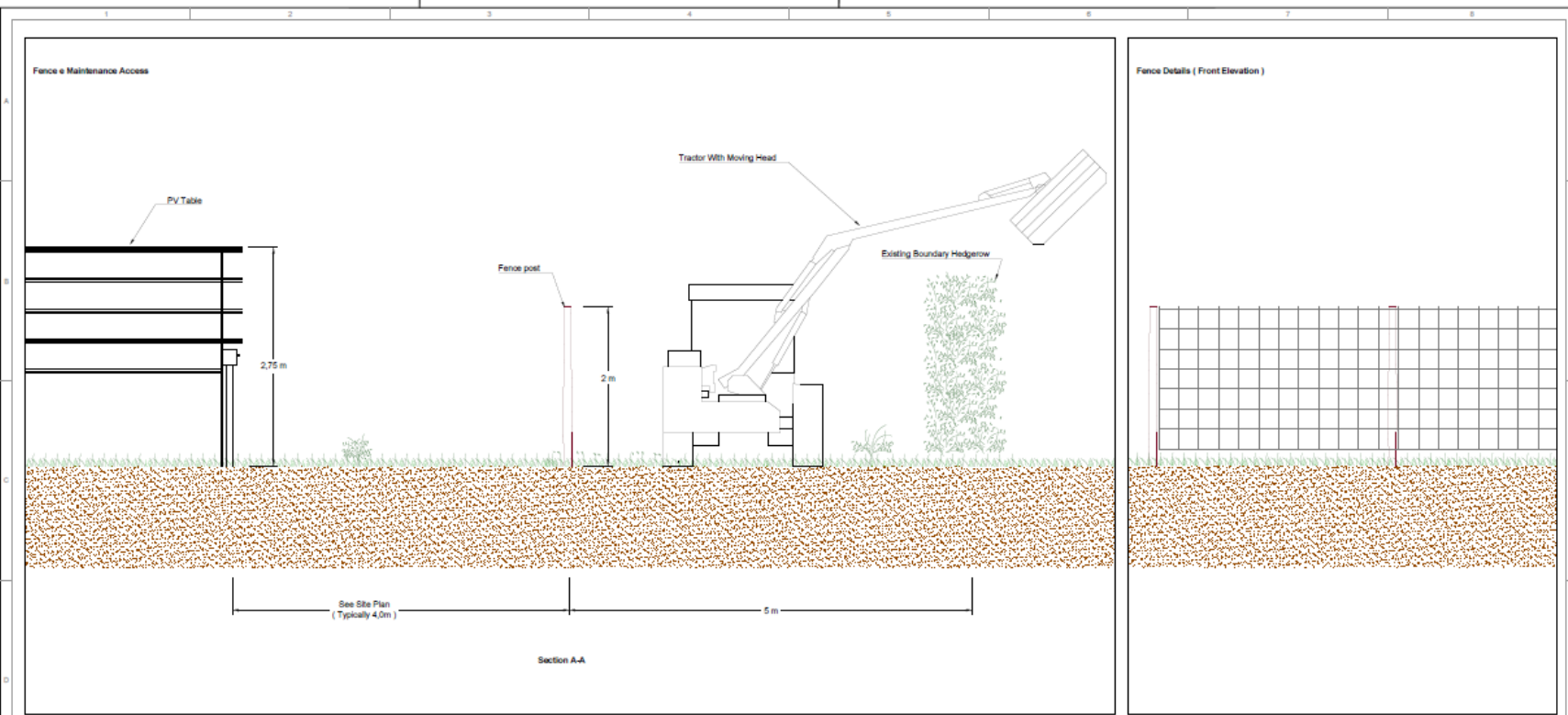

00	Issue Version	George Fungli	George Fungli	10.12.2019
VERSION	PURPOSE	DRAWN	VERIFIED	DATE
CLIENT:		DRAWN:	SERVICE:	Electrical
PROJECT:	BLAENHIREATH PV PLANT	VERIFIED:	STAGE:	Development
SITE:	Blaenhireath Farm, Llansamlet, SA14 8PX	DATE:	RELEASED BY:	GED
DRAWING DESIGNATION:	Mounting Structure and Fence Detail	SCALE:	VOLTALIA UK	
		PROJECT N°:	1 Lytch Square, Hammersmith	
		FORMAT:	W8 DNS London, United Kingdom	
		DRAWING N°:	Tel: +44 203941094	

Page 41

Security Fencing (Front Elevation)

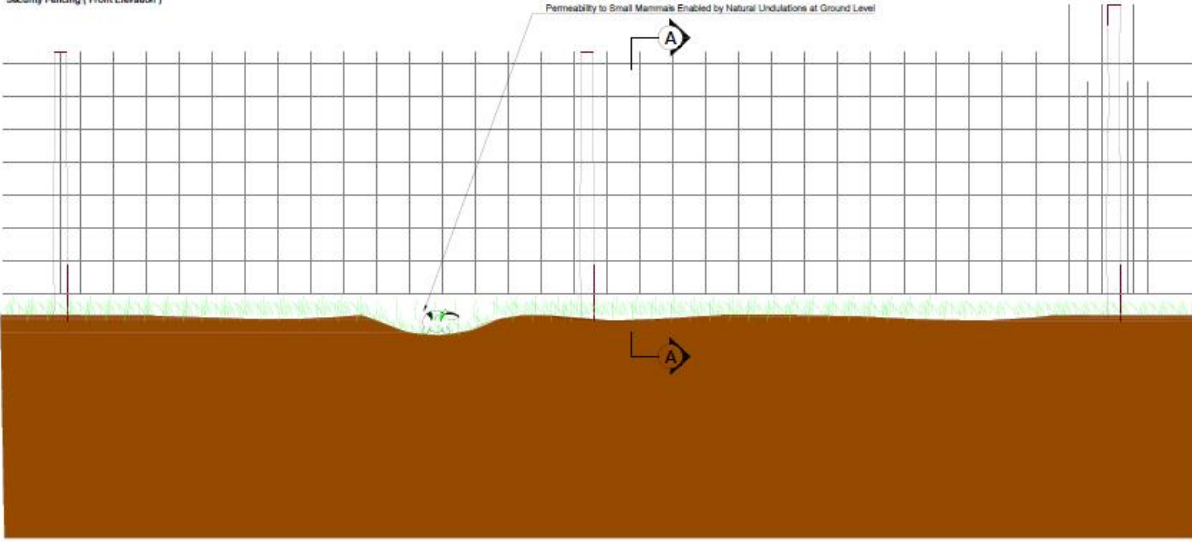

Security Fencing (Section A'A)

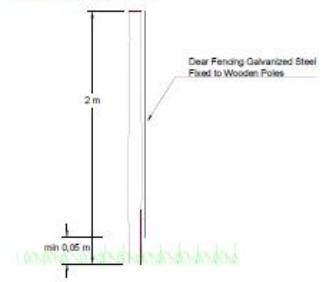

Security Fencing (Sample Images)



00	Initial version	George Fungit	George Fungit	10.12.2019	
VERSION	PURPOSE	DRAWN	VERIFIED	DATE	
CLIENT:	-	DRAWN:	George Fungit	SERVICE:	Electrical
PROJECT:	BLAENHIREATH PV PLANT	VERIFIED:	George Fungit	STAGE:	Development
SITE:	Blaenhireath Farm, Llangennech, SA14 8PX	DATE:	10.12.2019	RELEASED BY:	GED
DRAWING DESIGNATION:	Fence Details	SCALE:	1:50	VOLTALIA UK	
		PROJECT N°:	FCN01	1 Lyric Square, Harmerweth	
		FORMAT:	A3	WR 0N3 London, United Kingdom	
		DRAWING N°:	HN01_03_06_100_00	Tel: +44 203941084	



DNS/00422

PT007-TEC-FRM01/03/09.16 | This drawing is property of Voltalia SA and may not be reproduced, disclosed or copied in whole or in part without permission. All rights reserved by law.

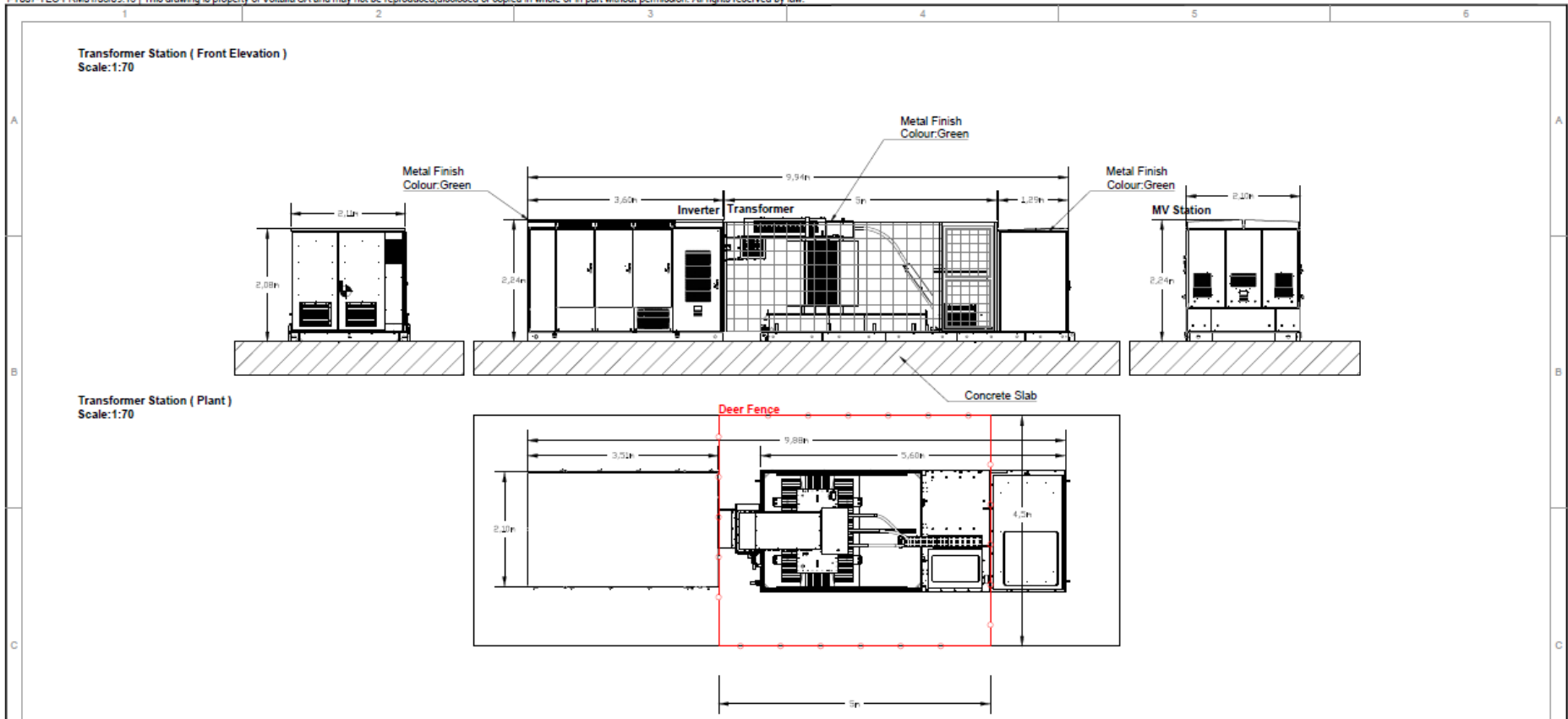

Page 43

00	Initial version	Giorgio Funghi	Giorgio Funghi	10.12.2019	
VERSION	PURPOSE	DRAWN	VERIFIED	DATE	
CLIENT:	-	DRAWN:	Giorgio Funghi	SERVICE:	Electrical
PROJECT:	BLAENHIREATH PV PLANT	VERIFIED:	Giorgio Funghi	STAGE:	Development
SITE:	Blaenhiraeth Farm, Llangennech, SA14 8PX	DATE:	10.12.2019	RELEASED BY:	GED
DRAWING DESIGNATION:	Transformer Center Connection Details	SCALE:	1:100	VOLTALIA UK	
		PROJECT N°:	PEN01	1 Lyric Square, Hammersmith	
		FORMAT:	A4	W6 0NB London, United Kingdom	
		DRAWING N°:	PEND_DV_HV_120_00	Tel: +44 2039941094	



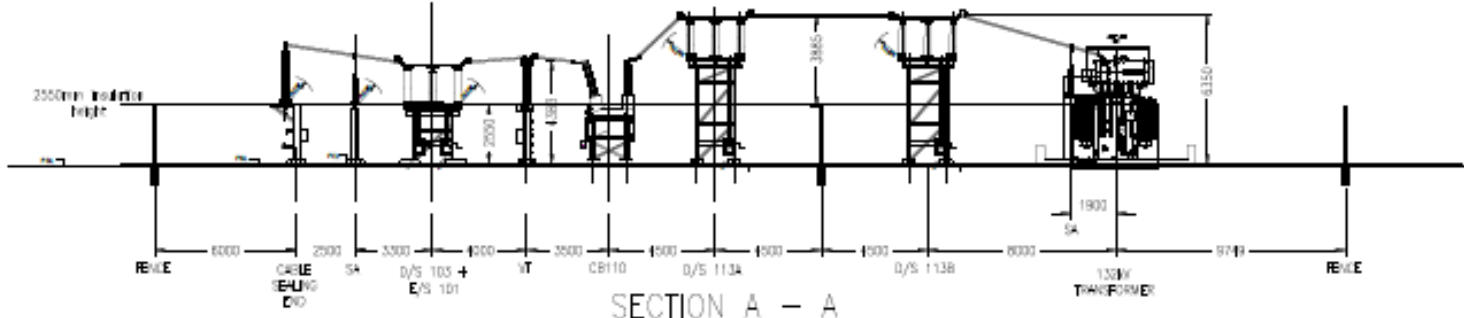

SECTION A - A

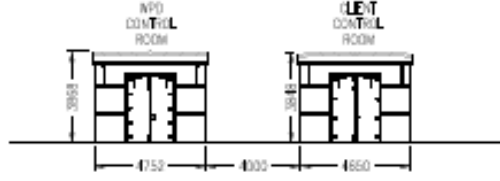

SECTION B - B

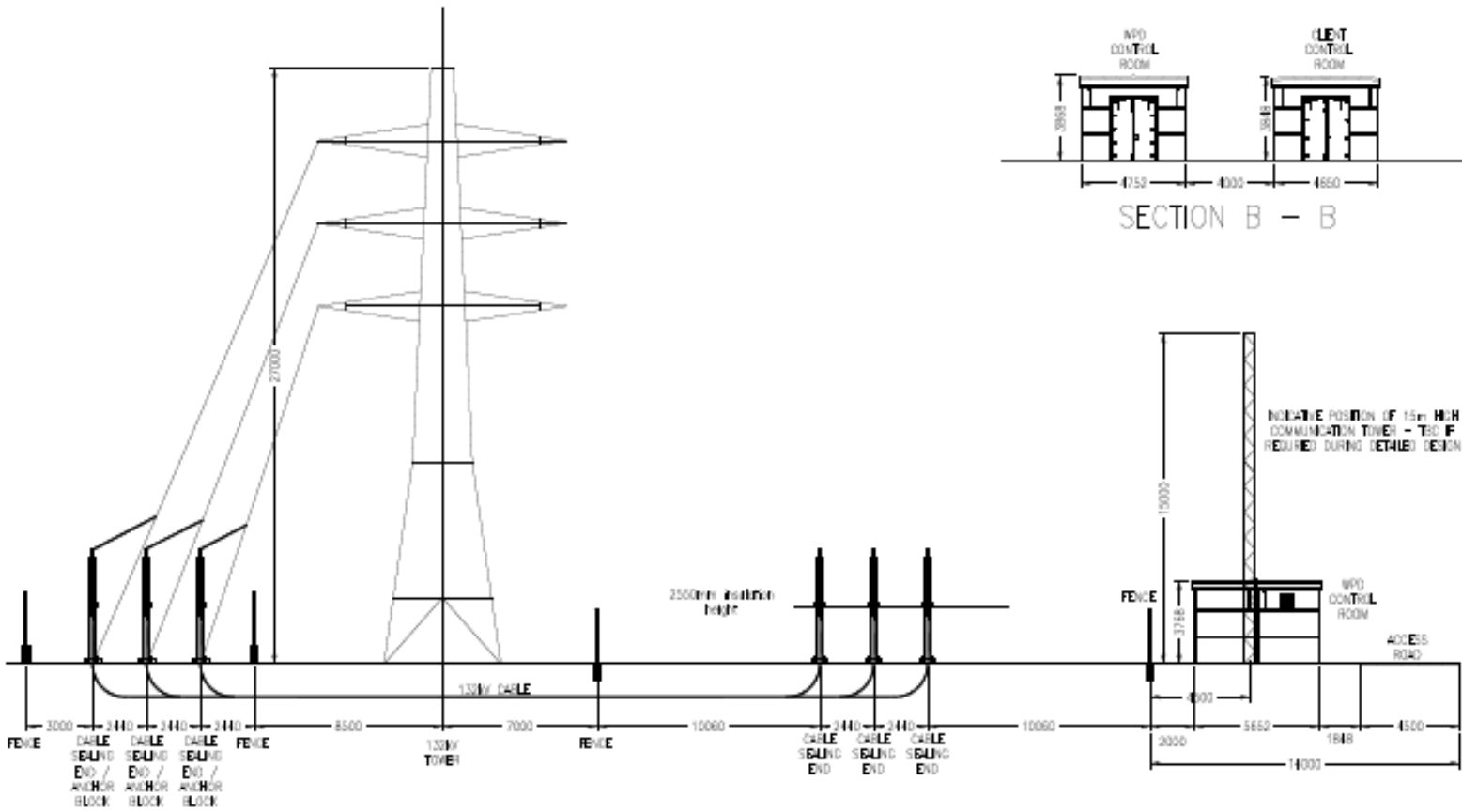

SECTION C - C

DNS/00422

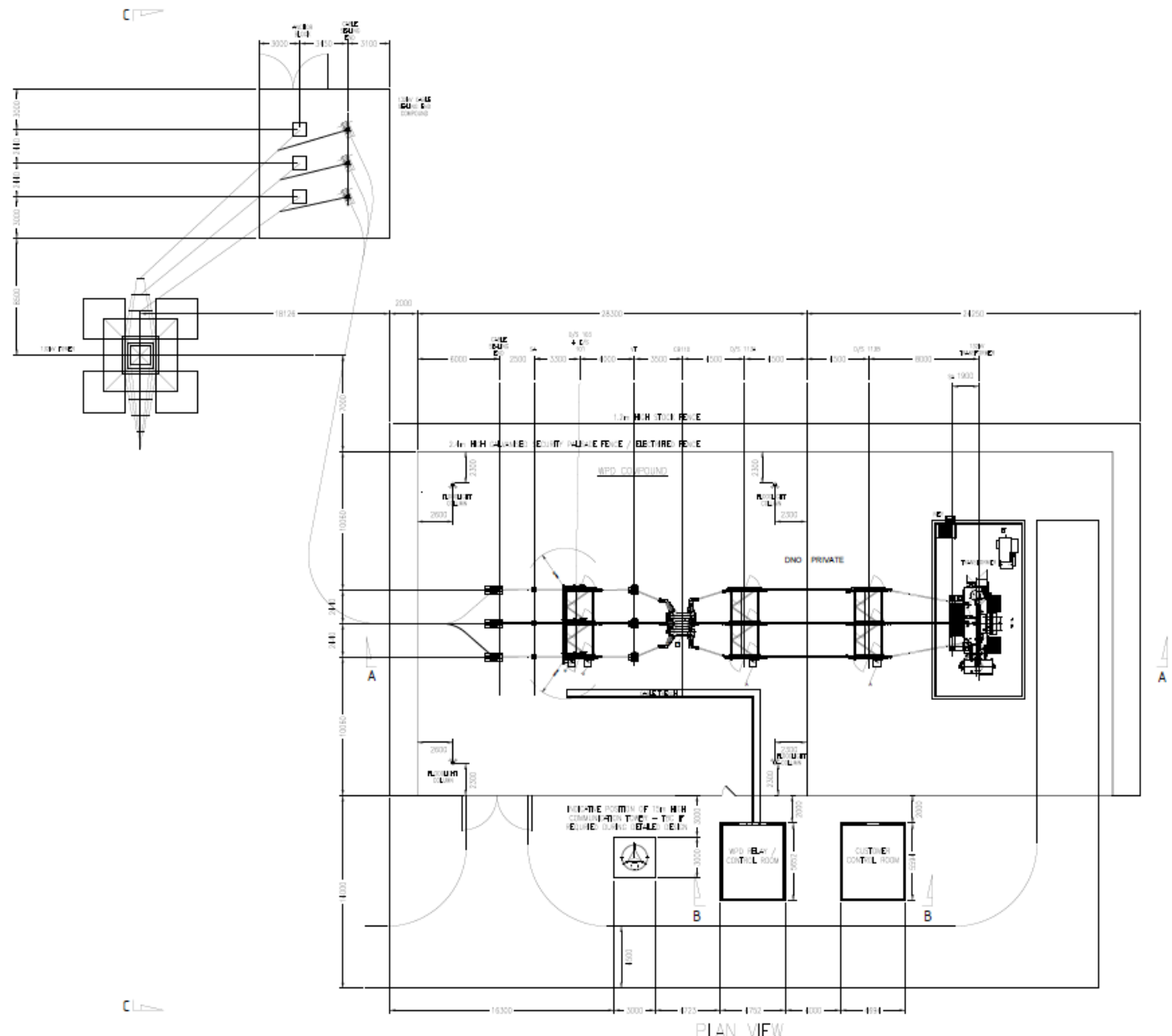

DNS/00422

CCTV Camara (Elevation)

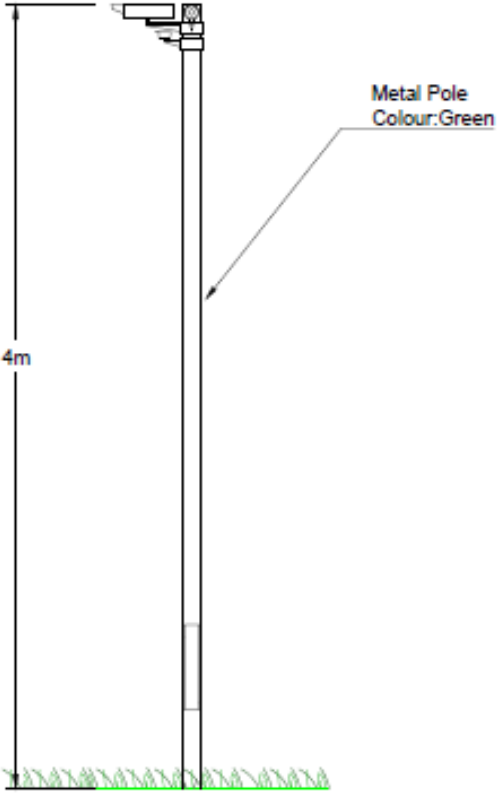

Control House (Front Elevation)

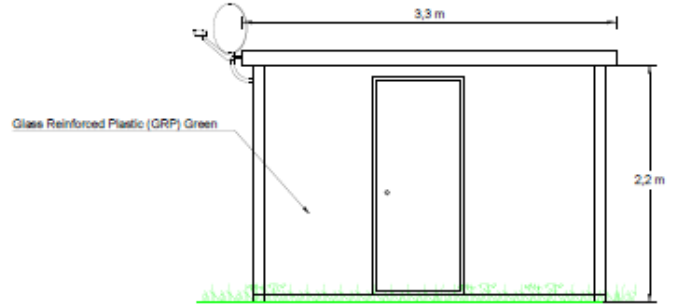

Control House (Side Elevation)

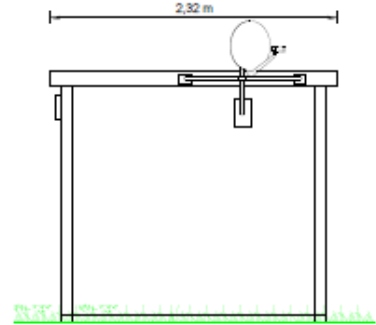

Control House (Rear Elevation)

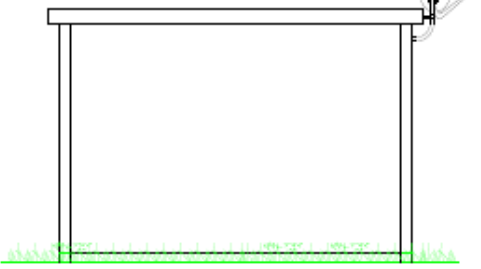

Control House (Roof Plan)

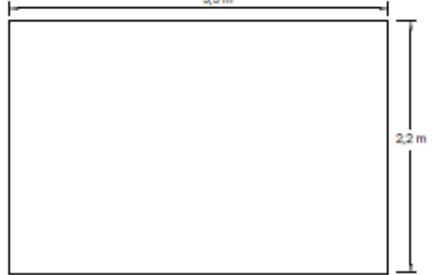

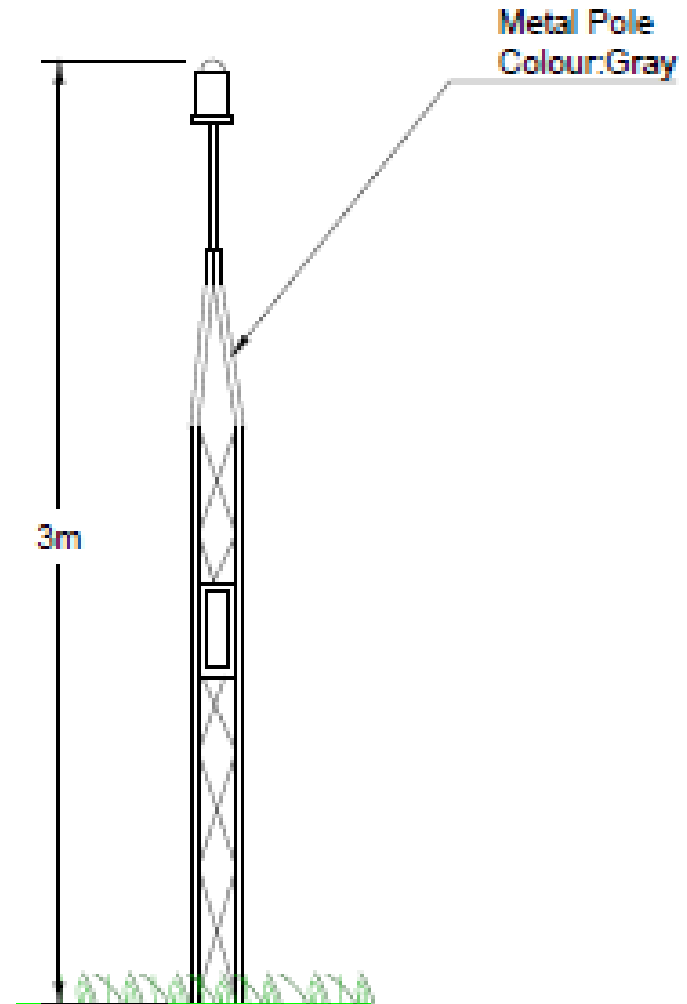



Camera make & model - Canon EOS 5D, FPS
Lens make & focal length - Canon EF 50mm, f/1.4 USM
Date & time of photograph - 23/10/2019 @ 13:31
OS grid reference - 254155, 205533

Viewpoint height (AOD) - 113.2m
Distance from site - 74.4m
Projection - Planar
Enlargement / Sheet Size - 100% @ A3

Visualisation Type - Type 1
Horizontal Field of View - 39.6°
Height of camera AGL - 1.5m
Page size / Image size (mm) - 420 x 297 / 390 x 260

Existing View 3. Keepers Lodge



Page 49

DNS/00422



Page 50



Camera make & model - Canon EOS 5D, FFS
Lens make & focal length - Canon EF 50mm, F1.4 USM
Date & time of photograph - 08/08/2019 @ 11:46
OS grid reference - 253545, 204551

Viewpoint height (AOD) - 149.2m
Distance from site - 383.4m
Projection - Planar
Enlargement / Sheet Size - 100% G A3

Visualisation Type - Type 1
Horizontal Field of View - 39.4°
Height of camera AGL - 1.5m
Page size / Image size (mm) - 420 x 297 / 390 x 260

Existing View
12. Penderi Farm

DNS/00422



Page 51

DNS/00422

94

Page 52



Camera make & model - Canon EOS 5D, FFS
Lens make & focal length - Canon EF 50mm, f/1.4 USM
Date & time of photograph - 08/08/2019 @ 11:08
OS grid reference - 253609, 204186

Viewpoint height (AOD) - 139.3m
Distance from site - 581.3m
Projection - Planar
Enlargement / Sheet Size - 100% @ A3

Visualization Type - Type 1
Horizontal Field of View - 39.6°
Height of camera AGL - 1.5m
Page size / Image size (mm) - 420 x 297 / 390 x 260

Existing View
20. Medelfwy Farm

DNS/00422



Page 53

